

# R15ID3S-MRM2

15" Intel Atom® N2600 Marine Panel PC



## KEY FEATURES

- Intel Atom® N2600 dual-core Marine Panel PC
- Dimming knob control backlight brightness from nearly 0% to 100%
- Transflective film technology enhances visibility
- Panel (flush) mount IP66 aluminum housing with powder coating design (IP54 rear)
- 9~36V DC power input acceptable

## INTRODUCTION

Winmate Marine Panel PC Series is purpose-built for maritime environments, offering sizes from 10.4" to 24" with a rugged aluminum housing and IP66-rated panel mount design. Certified to meet DNVGL-CG-0339, IEC60945, and IACS-E10 standards, these panel PCs deliver reliable performance in demanding marine applications. Equipped with hyper dimming technology for seamless brightness adjustment from 0% to 100% and optional transflective film for enhanced outdoor visibility, they ensure safe operation in all lighting conditions. With versatile OS support, 9~36V DC power input, and robust construction, these PCs are ideal for navigation and monitoring systems.

## SPECIFICATIONS

### Display

Touch / Glass	Resistive Touch Screen (Default) AR Glass (Optional)	Resolution	1024x768
Size	15.0 inches	Contrast Ratio	2000:1
Panel Brightness	300.0 nits	View Angles	88,88,88,88
Active Area	304.1x228.1 mm		

### System Specification

Processor	Intel Atom N2600 1.6GHz	Chipset	Intel® NM10
Memory	4GB	Storage	128GB (Default) up to 512GB (Optional)
Ethernet controller	BCM57780A1KMLG	Operating System	Windows 7 Embedded Systems (Optional)

### Environment

Operating Humidity	5% to 95%	Operating Temperature	-15~55°C
Shock	15G, 11ms duration	Vibration	0.7g@DNV-CG-0339 (Class A)
IP rating	IP66 (Front Side)		

### Certification

Certification	CE, FCC DNV-CG-0339, IEC60945 4th, IACS E10
---------------	--

### Mechanical

Dimension	412 x 345 x 71.7 mm	Weight	6.5 kg
-----------	---------------------	--------	--------

Mounting	VESA mount/Panel mount	Enclosure	Metal Housing with Aluminum Bezel
Cooling System	Fanless Design	Cut out	338 x 288mm
<b>IO Ports</b>			
USB Port	2 x USB2.0	Serial Port	1 x RS232/422/485 2 x RS232 or 2 x Isolation RS422/485
Video	1 x VGA	LAN	2 x RJ45-10/100/1000 Mbps
<b>Accessory</b>			
Accessory	Driver CD & User Manual 4 x M6 Black Screw Bolt with M6 Nut 1 x AC Adapter 12V/ 84W 1 x Power Cord		
<b>Power</b>			
Power Rating	24V DC-in with Isolation (Approval by Certificate) 9~36V DC Input Acceptable	Consumption	40W (Typical)
<b>Control</b>			
Button	1 x Power Button 1 x Reset Button 1 x The Dimming Knob		

**DIMENSIONS** UNIT:MM

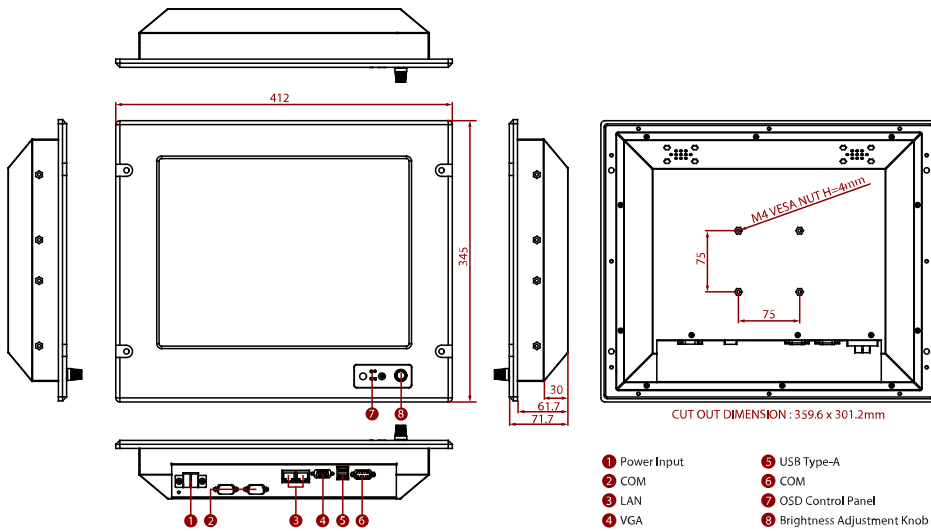

**NOTE**

1. This is a simplified drawing and some components are not marked in detail.
2. Only 24 V DC has been approved by DNVGL certification.
3. Please contact our sales representative if you need further product information.
4. All specifications are subject to change without prior notice.
5. The product shown in this datasheet is a standard model. For diagrams that contain customized or optional I/O, please contact the Winmate Sales Team for more information.